

(= MIN. RADSTAND BEI AGGREGATANORDNUNG)  
 (= MIN. WHEEL BASE IF FITTED AS MULTI AXLE SUSPENSION)

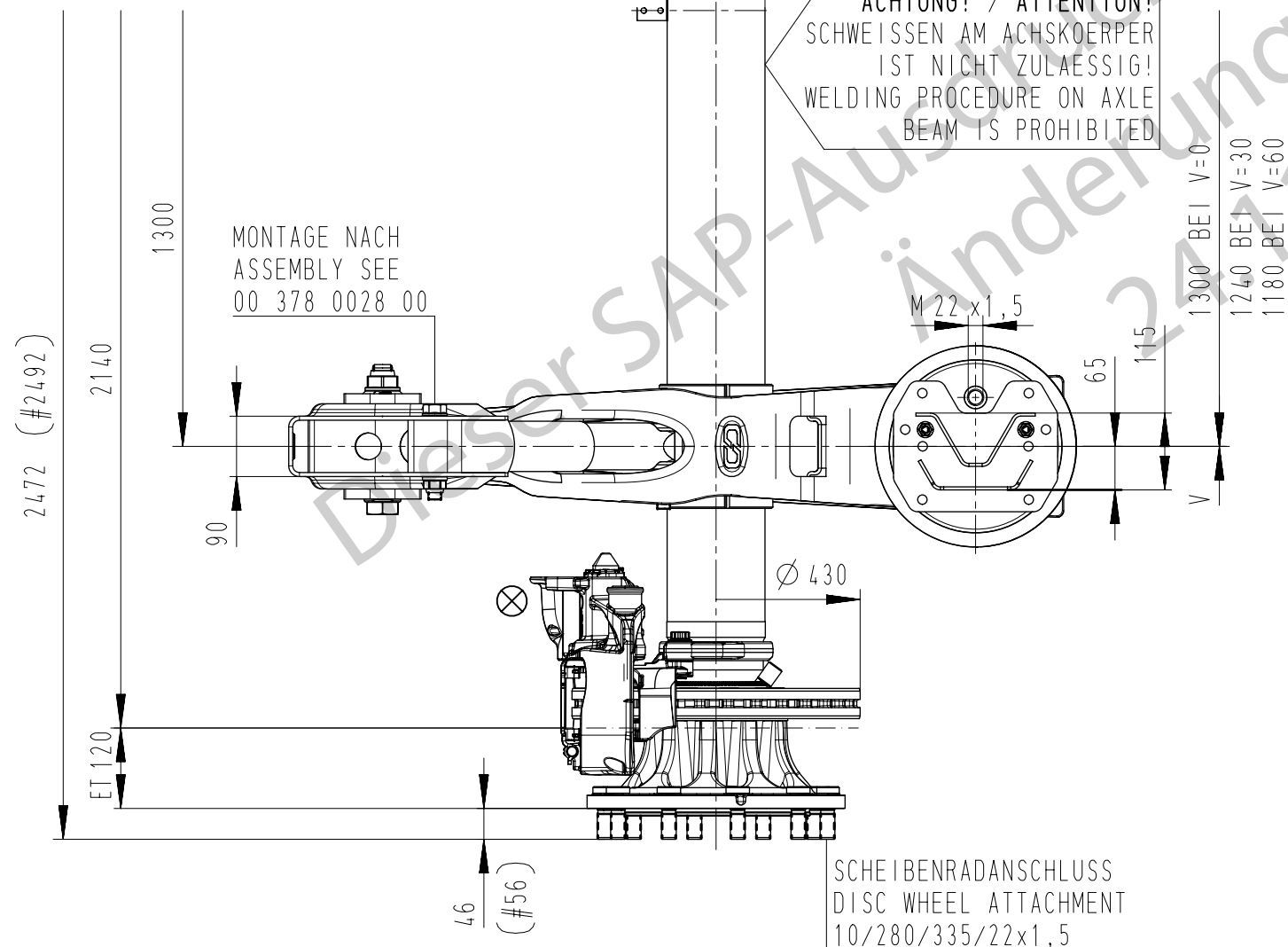

GESAMTFEDERWEG  
TOTAL AXLE TRAVEL

FAHRHOEHENBEREICH / RIDE HEIGHT RANGE			BAUHOEHE OHNE LUFT / HEIGHT WITHOUT AIR	
FUER EINZELACHSEN FOR SINGLE AXLES	FUER ACHSAGGREGATE FOR AXLES SYSTEMS	FUER ACHSAGGREGATE MIT LIFT FOR AXLES SYSTEMS WITH LIFT	LEER / UNLADEN ca. / approx	BELADEN / LADEN ca. / approx
395-445	405-445	435-445	335	320
F			X	



⊗ FÜR ANGRENZENDE BAUTEILE  
 VERSCHLEISS-VERSCHIEBUNG DES  
 SATTELS VON 30mm BEACHTEN  
 EVTL. FREIMACHUNG AM RAHMEN ERFORDERLICH  
 FOR ADJACENT PARTS RESPECTS THE  
 CALLIPER DISPLACEMENT OF 30mm  
 DUE TO THE PAD AND DISC WEAR  
 FREESPACE MAY BE REQUIRED ON THE CHASSIS

INFO: VERSTREBUNG / BRACING

<http://designmanual.safholland.de>

DER FAHRZEUGRAHMEN IST SO AUSZUSTEIFEN, DASS ER DIE EINGELEITETEN KRAEFTE AUFNEHMEN KANN. DIE HALTEBOECKE DER LUFTFEDERUNG MUESSEN ZUSAETZLICH VERSTREBT WERDEN. ALMOST ALL FORCES ARE PASSED INTO TRAILER FRAME THROUGH FRONT HANGERS. THEREFORE TRAILER FRAME MUST BE STRENGTHENED AND HANGERS MUST BE BRACED.

OPTION: ACHSE PREMIUM COATED 00 516 0005 00  
 AXLE PREMIUM COATED

SPECIALS:

OPT IONS	ABS-SENSOREINBAU / INSTALLATION OF ABS CABLE	03 029 1064 00
	ZAEHNEZAHL / NUMBER OF TEETH	90
	RADKAPPE FÜR HUBODOMETER WHEEL CAP FOR ODOMETER	03 304 0103 02
	ABDECKBLECH GRUPPE COVER PLATE ASSEMBLY	03 005 0284 00
	2-SEITENLIFT 2 SIDED LIFT	03 027 1278 01

CD = CUSTOM DESIGN

STAHL-RAEDER STEEL WHEELS	KIT ACHSE / AXLE	747 91 05 7 48 21	ALU-RAEDER ALU WHEELS	KIT ACHSE / AXLE	#1 747 91 05 7 49 21
------------------------------	---------------------	-------------------	--------------------------	---------------------	----------------------

ACHSLAST AXLE LOAD	9 000 kg	bei at	105 km/h	REIFEN-BEISPIEL TIRE EXAMPLE	385/65 R 22,5	NOCKENWELLE CAMSHAFT	57055
-----------------------	----------	-----------	----------	---------------------------------	---------------	-------------------------	-------

AEL	SEL	GRUNDPLATTENSTELLUNG BRAKE CHAMBER BRACKET POSITION
-----	-----	--

DATE	NAME	ACHSE MIT LUFTFEDERUNG AXLE WITH AIR SUSPENSION			
DR 2020-09-10	FERSCH	B19-22S01 - 1042/3005 33			
CH 2020-11-19	PROESSLER	BREMSE BRAKE	SBS2220 K0	TEST REPORT	36102214
SIZE	A3	ID			
SCALE	1:10	282963174821 -			

THIS DOCUMENT CONTAINS PROPRIETARY CONFIDENTIAL INFORMATION OWNED BY SAFHOLLAND GmbH AND ITS SUBSIDIARY COMPANIES. THIS DOCUMENT AND THE INFORMATION IN IT ARE NOT TO BE USED, DISCLOSED OR REPRODUCED WITHOUT THE EXPRESS WRITTEN PERMISSION OF THE OWNER.

ERSATZ FÜR / REPLACES